

Sheet Metal Enclosed Motor Disconnect Switch



- UL Type 4
- Excellent in harsh weather conditions
- Resistant to many chemicals
- Corrosion and UV resistant
- IP65 Protection Level
- Lockable - Defeatable Handle



NEW

NEW

All Models are lockable with up to 3 padlocks.

Catalog Number

Black Handle	KET316UL	KET325UL	KET340UL	KET360UL	KET380CUL
Yellow/Red Handle	KET316UL Y/R	KET325UL Y/R	KET340UL Y/R	KET360UL Y/R	KET380CUL Y/R
No. of Poles	3 (4 pole - KET416UL (Y/R))	3 (4 pole - KET425UL (Y/R))	3 (4 pole - KET440UL (Y/R))	3 (4 pole - KET460UL (Y/R))	3 (4 pole - KET480CUL (Y/R))
General Purpose Current	16 A	25 A	40 A	60 A	80 A
Maximum Voltage	600V AC	600V AC	600V AC	600V AC	600V AC
Motor FLA @ 480V AC	14 A	21 A	27A	34A	40 A
Motor FLA @ 600V AC	9A	11A	17A	27A	32A

Horsepower Rating/HP	1 Phase	3 Phase	1 Phase	3 Phase	1 Phase	3 Phase	1 Phase	3 Phase	1 Phase	3 Phase
110-120V AC	1	2	1.5	3	2	3	3	5	5	7.5
200V AC	1.5	3	2	5	3	7.5	5	10	7.5	10
208V AC	1.5	3	2	5	3	7.5	5	10	7.5	10
220-240V AC	2	3	3	5	5	7.5	7.5	10	10	15
265V AC	-	5	-	7.5	-	10	-	10	-	15
277V AC	-	5	-	7.5	-	10	-	10	-	15
380-415V AC	-	7.5	-	10	-	15	-	20	-	25
440-480V AC	-	10	-	15	-	20	-	25	-	30
550-600V AC	-	7.5	-	10	-	15	-	25	-	30

Short Circuit Withstand Rating at 600 V with Max. Fuse Size/Class:	10 kA	10 kA	10 kA	10 kA	10 kA
K5	30 A	30 A	30 A	30 A	30 A
RK5	30 A	30 A	30 A	30 A	30 A
RK1	60 A	60 A	60 A	60 A	60 A
J	80 A	80 A	80 A	100 A	100 A

Terminal Size

Acceptability	14-8 AWG	14-8 AWG	14-8 AWG	12-4 AWG	12-4 AWG
(Cu Conductors only, 75 °C)					
Terminal Torque	16 lb. in. (1.8 Nm)	16 lb. in. (1.8 Nm)	16 lb. in. (1.8 Nm)	16 lb. in. (1.8 Nm)	16 lb. in. (1.8 Nm)
Screw Head Type	No. 2 Pozidrive	No. 2 Pozidrive	No. 2 Pozidrive	No. 2 Pozidrive	No. 2 Pozidrive
Environmental Rating	UL Type 4	UL Type 4	UL Type 4	UL Type 4	UL Type 4
Enclosure Type Used	TR007	TR007	TR007	TR01	TR01

Dimensions

(to convert to inches multiply by 0.03937)

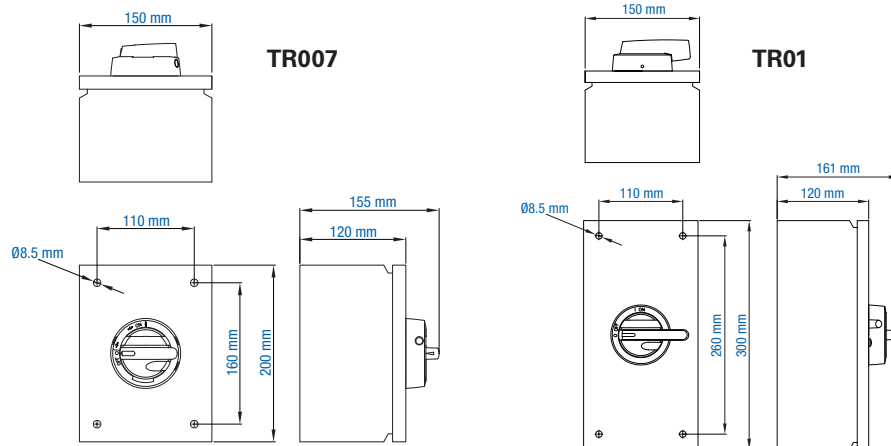

Enclosure Cover Screw Installation (Additional Information)

Enclosure	Screw Type	Torque
TR007	PH2	10.6 lb. in. (1.2 Nm)
TR01	PH2	10.6 lb. in. (1.2 Nm)
TR02	☺	Key lock

Weight	2.1 kg (4.63 lb.)	2.1 kg (4.63 lb.)	2.1 kg (4.63 lb.)	4.0 kg (8.82 lb.)	4.3 kg (9.48 lb.)
--------	-------------------	-------------------	-------------------	-------------------	-------------------

Suitable Accessories

Auxiliary Contacts	KU1.V, KU2.V	KU1.V, KU2.V	KU1.V, KU2.V	KU1.V, KU2.V	VKA1.V, VKA2.V
--------------------	--------------	--------------	--------------	--------------	----------------